

E17

Signal to Noise Ratio

Giacomo Langfelder
giacomo.langfelder@polimi.it

06/12/2023

PROBLEM

Your company develops cheap digital still cameras that feature a 3T CMOS active pixel sensor (APS). Each pixel occupies an area of $(3 \mu\text{m})^2$, with a fill factor of 45%. The technology used by the foundry for the production of the sensor allows a maximum voltage of 3.3 V. The technology has been optimized for image acquisition, giving a quantum efficiency of 0.65. In operation, each photodiode is reverse biased and its depletion region is $1 \mu\text{m}$ wide. The dark current density is $50 \text{ aA}/\mu\text{m}^2$. The output node is directly connected to an 8-bit analog-to-digital converter (ADC). For an integration time of 10 ms, you are interested in:

1. finding the photocurrent, the conversion gain, and the pixel sensitivity when a photon flux of 10^{16} ph/s/m^2 hits the sensor (neglect the MOS gate capacitance);
2. listing and calculating all noise sources in e_{rms} ;
3. evaluating the signal to noise ratio and graphing it vs the integration time.

INTRODUCTION (1): MODELING OF THE PHOTODIODE

It is well known that a reversely biased pn junction can be used to implement a photodiode. In this configuration, with a fixed voltage applied to the junction, the energy band

diagram is schematically represented as in Fig. 1.

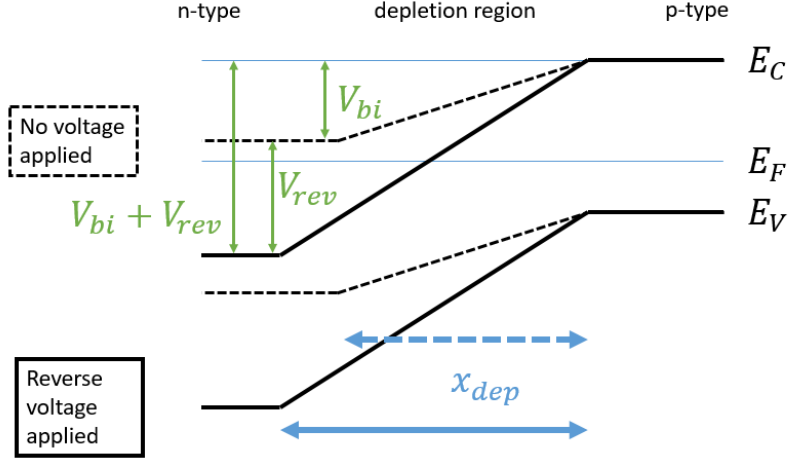

Figure 1: Schematic representation of the valence and conduction bands in a reverse-biased pn junction.

In this condition, the depletion region represents a volume void of free carriers, and thus it can be interpreted as a dielectric; the undepleted regions, on the contrary, remain somewhat conductive due to the excess of carriers given by the doping. A reverse-biased photodiode thus shows a physical depletion capacitance,

$$C_{PD} = \frac{\epsilon_0 \epsilon_r A_{active}}{x_{dep}},$$

where A_{active} is the photodiode active area, x_{dep} is the extension of the depletion region and $\epsilon_r = 11.7$ is the electrical permittivity of silicon relative to vacuum (ϵ_0). In a typical active pixel, the active area of the photodiode is lower than the overall pixel area, due to the fact that, within a single pixel, alongside the photodiode, also the source follower and two switches are present, as you can see in Fig. 2. The ratio between the two surfaces is called fill-factor:

$$A_{active} = FF \cdot A_{pix}.$$

With the provided numbers, the depletion capacitance of the photodiode is 0.42 fF. Remember that the extension of the depletion region is itself a function of the reverse voltage. When considering a one-sided n^+p junction, the depletion width is

$$x_{dep} = \sqrt{\frac{2\epsilon_0 \epsilon_r (V_{rev} + V_{bi})}{qN_A}}.$$

In principle, when the voltage across the photodiode changes, the depletion width changes and hence the capacitance, giving rise to some nonlinearity. This simple pn junction is still one of the most used structures as the basic building block in the implementation of ultra-small-area pixels for digital imaging sensors.

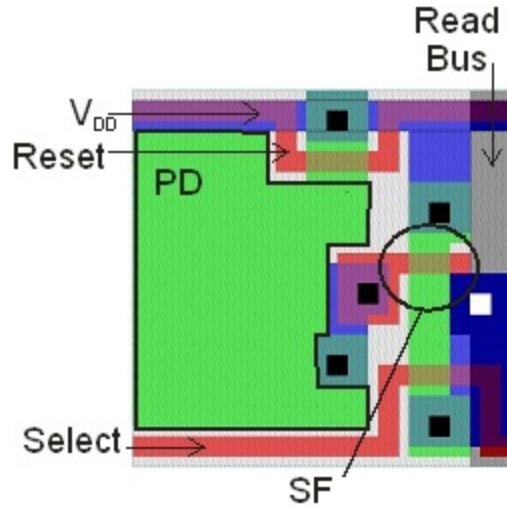

Figure 2: Layout of a typical 3T active pixel.

If we draw the electrical model of a photodiode, we can thus place the depletion capacitance, C_{PD} , between the anode and the cathode electrodes. It is then also known that pn -junctions are characterized by their dark current: the dark current flows through photo-sensitive devices even when no outside radiation is entering the detector; physically, dark current is due to thermal generation of electrons and holes within the sensitive volume; we can place the dark current generator, i_{dark} , in parallel to the photodiode capacitance and possible parasitics. We can then add the signal generator, i_{ph} , that models the photocurrent, due to radiation (photons) impinging on the photodetector. We can finally add a current noise source, that models the shot noise due to the discrete nature of the electric charge that flows through the photodiode; remember that shot noise in a photodiode is due to both the photocurrent and the dark current. The complete small-signal model of the photodiode is shown in Fig. 3.

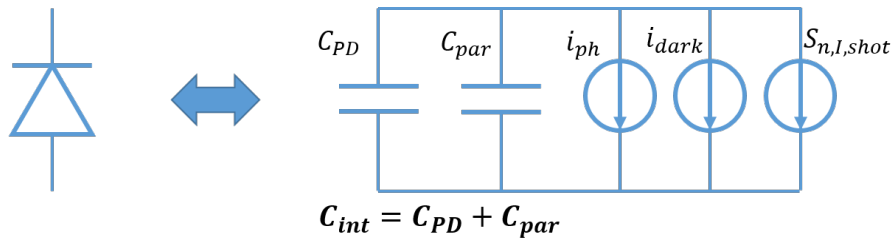

Figure 3: Small-signal model of a photodiode.

INTRODUCTION (2): MODELIZATION OF THE READOUT CHAIN

There exist categories of sensors where each photodiode is simply connected to rows and columns by means of select switches (MOS transistors). In this configuration, a row decoder and a column-selecting multiplexer sequentially scan the matrix, connecting each pixel to a single amplifier, designed aside of the photodiodes matrix. This addressing scheme is much similar to the one used for memories. A sensor that exploits this kind of readout scheme is defined a *passive pixel sensor* (PPS), meaning that within each pixel there is no function other than passive photons absorption and generation of electron-hole pairs.

On the other side, there are sensor topologies where part of the readout electronics is designed close to each *pn* junction, within the pixel itself. The single picture element thus provides a pre-amplification of the signal from charge to voltage, and a low output impedance with advantages in that: (i) problems of charging large parasitic capacitances of row and column buses are limited, and (ii) sensor readout can be very fast (the time needed for the readout of each pixel is short). Among the drawbacks of the *active pixel sensor* (APS), we note that (i) the active area for photons collection is only a fraction of the overall pixel area and the fill factor is thus far from PPS values, and (ii) gain and offset can be slightly different among different pixels (giving rise to spatial noise).

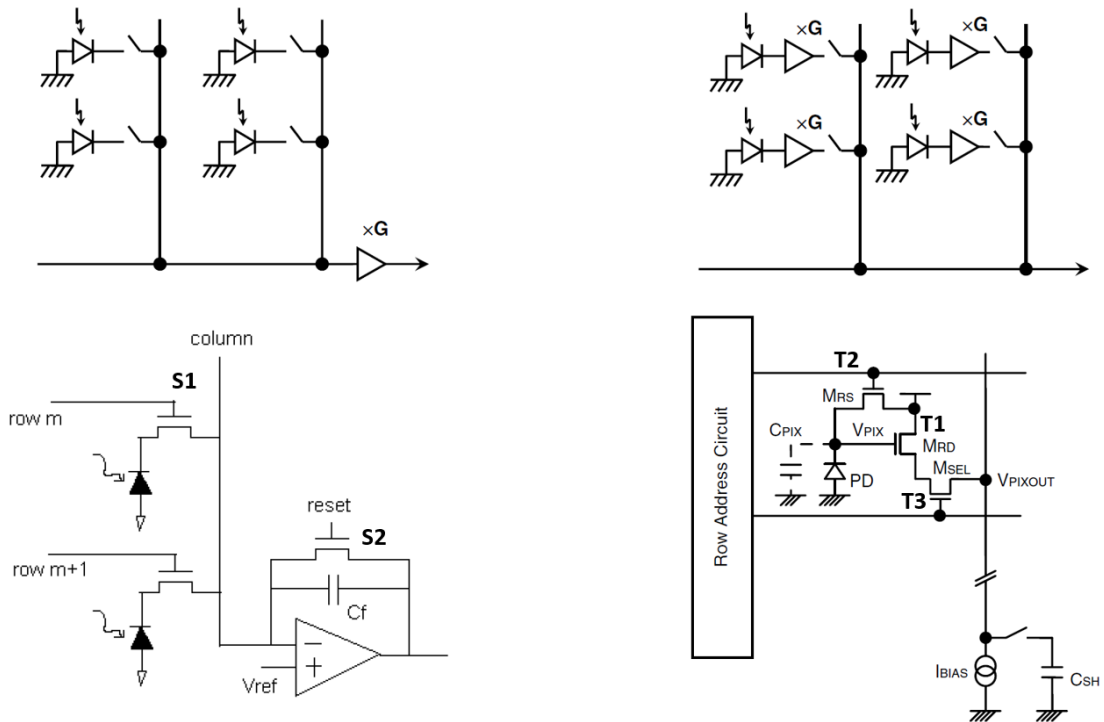

Figure 4: Schematic representation of CMOS PPS (left) and APS (right) readout.

Regardless of the readout scheme, signal pre-amplification is a conversion from charge to voltage. Usually, the p terminal of the photodiode is grounded while the n region is first reset to a fixed voltage ($1 - \text{Reset}$). Then, it is left electrically floating: with the reverse bias condition being held, photo- or dark-generated electrons tend to collect at the n region, reducing its potential, while holes flow to the ground terminal ($2 - \text{Integration}$); all CMOS image sensors for DSC (digital still camera) applications operate with this *charge-integrating mode*. At the end of the integration, a voltage signal proportional to the number of generated photoelectrons is available to be read out ($3 - \text{Readout}$).

Let us consider Fig. 4 (left), which represents an amplifier that can be used to read the signal out of a PPS.

1. the output is initially *reset* to V_{ref} by closing both switches S1 and S2. In this configuration the photocurrent of the diode does not determine any change in the output voltage, as it flows through the short circuit due to S2 from the (low-impedance) output of the operational amplifier;
2. in the second phase (*integration*), switch S1 is kept open together with the camera shutter (and also after the shutter is closed until the readout of the pixel): the photo- and the dark currents are collected on the photodiode capacitance, whose voltage decreases during the integration t_{int} (see the model in Fig. 3):

$$V_{PD}(t) = V_{ref} - \Delta V_{PD}(t), \quad \Delta V_{PD}(t) = \frac{(i_{ph} + i_d)t}{C_{int}};$$

C_{int} is the integration capacitance, given by the sum of the diode capacitance and other parasitic capacitances that are present from the integration node to ground. At the end of the integration time,

$$\Delta V_{PD} = \frac{(i_{ph} + i_d)t_{int}}{C_{int}};$$

3. finally, in the *readout* phase, S1 is closed again soon after S2 is opened: the sudden voltage change across the diode capacitance determines a current pulse flowing in the feedback loop of the amplifier, so that the output voltage increases:

$$V_{out} = V_{ref} + \Delta V_{PD} = V_{ref} + \frac{(i_{ph} + i_d)t_{int}}{C_F}.$$

The readout operation is consecutively repeated for all the pixels.

Similarly, considering Fig. 4 (right), which represents the readout electronics of a 3T (i.e. three transistors) active pixel matrix, the readout occurs in the following way:

1. the integration node is first *reset* to a value equal to V_{DD} by closing the reset switch implemented with transistor T2;

- then, T2 is opened and the photocurrent gets *integrated* on the integration capacitance. At the end of the integration time, we have:

$$V_{PIX} = V_{DD} - \frac{(i_{ph} + i_d) t_{int}}{C_{int}};$$

the voltage drop, ΔV_{PD} , is proportional to the photocurrent;

- finally, the follower transistor is biased closing switch T3, so that the voltage at the follower gate is buffered to the pixel output.

It should be underlined that, during integration, the voltage across the photodiode changes; hence, its depletion width and, in turn, its capacitance change, as well. Modeling the photodiode as a constant capacitance equal to C_{PD} is thus a partial approximation.

PART 1: SENSITIVITY AND SIGNAL

The signal-to-noise can be calculated either in terms of voltage, or current, or charge. In all our examples, we will calculate it in terms of charge. In particular, as usually done in digital imaging, we will evaluate it in terms of number of electrons, by simply dividing the charge (expressed in Coulombs) by the elementary electron charge, e . Let us start by evaluating the signal. We can calculate the photocurrent as

$$i_{ph} = q\eta A_{active}\phi_{ph} = q \cdot \eta \cdot A_{pixel} \cdot FF \cdot \phi_{ph} = 4.2 \text{ fA}.$$

With a constant photocurrent, the photocharge can be easily evaluated as

$$Q_{ph} = \int_0^{t_{int}} i_{ph} dt = i_{ph} t_{int} = 4.2 \text{ fA} \cdot 10 \text{ ms} = 4.2 \cdot 10^{-17} \text{ C}.$$

Hence, the number of collected electrons is

$$N_{ph} = \frac{Q_{ph}}{q} = 263 \text{ electrons}.$$

If one wanted to calculate the signal in terms of voltage, he could exploit the conversion gain, defined as the ratio of the output voltage drop and the number of photogenerated electrons:

$$G = \frac{\Delta V_{PD}}{N_{ph}} = \frac{q}{C_{PD}} = 380 \mu\text{V}/e, \quad \Delta V_{PD} = G \cdot N_{ph} = 100 \text{ mV}.$$

The sensitivity, expressed as the output voltage drop over the input photon flux, is thus:

$$S = \frac{\Delta V_{PD}}{\phi_{ph}} = 1 \times 10^{-17} \text{ V/ph}/\text{m}^2/\text{s}.$$

This corresponds to the voltage drop experienced at the integration node at the end of the integration phase. It is also possible to compute the value of the integration capacitance (this gives rise to a non-linearity!) at the end of the integration phase:

$$C_{PD,new} = C_{PD} \frac{\sqrt{3.3V + V_{bi}}}{\sqrt{3.2V + V_{bi}}} = 0.425 \text{ fF}.$$

PART 2: NOISE

Three types of fundamental temporal noise mechanisms exist in optical and electronic systems: *thermal noise*, *shot noise*, and *quantization noise*.

Thermal noise comes from thermal agitation of electrons within a resistance. It is also referred to as Johnson-Nyquist noise. The power spectral density of the thermal noise in a voltage representation is given by

$$S_{n,V} = 4kTR \quad [\text{V}^2/\text{Hz}]$$

where k is Boltzmann constant, T is the absolute temperature, and R is the resistance. Shot noise is generated when a current flows across a potential barrier. It is observed in semiconductor devices, such as pn diodes, bipolar transistors, and sub-threshold currents in a MOS transistor. In CCD and CMOS image sensors, shot noise is associated with both incident photons and dark current. A study of the statistical properties of shot noise shows that the probability that N particles, such as photons and electrons, are emitted during a certain time interval is given by the Poisson probability distribution. Its power spectral density, in terms of current, can be expressed as

$$S_{n,I} = 2qi \quad [\text{A}^2/\text{Hz}]$$

The power spectral densities of thermal noise and shot noise are constant over all frequencies (white noise). Given a certain white noise spectral density, we can calculate the corresponding rms noise, i.e. the standard deviation of the signal from its mean value:

$$\sigma = \sqrt{\int_0^\infty S_{noise} df}, \quad \sigma = \sqrt{S_{noise} BW_{eq}},$$

where BW_{eq} is the *noise equivalent bandwidth* of the system/filter.

We are now ready to calculate all temporal noise contributions. We will evaluate them one by one. We will then sum them up (quadratically!) and we will be ready to calculate the signal-to-noise ratio.

Let's start with **shot noise**. The total current flowing in a photodiode is due to two different sources: the signal current (photocurrent) and the dark current (with density J_d). The rms shot noise is thus:

$$\sigma_{shot,i} = \sqrt{2q(i_{ph} + i_d) \frac{1}{2t_{int}}} = \sqrt{\frac{q(i_{ph} + i_d)}{t_{int}}}, \quad i_d = J_d \cdot A_{pix} \cdot FF = 0.2fA$$

since $1/(2t_{int})$ is the noise equivalent bandwidth of a discrete-time integrator, as the one inherently used during integration. We can express the two shot noise contributions in terms of charge:

$$\sigma_{ph,Q} = \sigma_{ph,i} t_{int} = \sqrt{q i_{ph} t_{int}}, \quad \sigma_{dark,Q} = \sigma_{dark,i} t_{int} = \sqrt{q i_d t_{int}}.$$

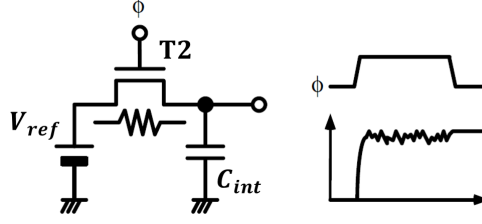

Figure 5: Simplified model for the kTC noise.

A further noise contribution is due to the periodical reset of the integration capacitance. When a capacitance is reset, noise called **reset** or **kTC noise** appears at the capacitance node when the switch is turned off. This noise comes from the thermal noise of the MOS switch. Fig. 5 shows an equivalent circuit of the reset operation. A MOS transistor (T2) is considered a resistance R_{on} during the on period, and thermal noise appears. When the switch opens, this noise is then sampled and held by the capacitor; different pixels will (randomly) sample different voltages; in video acquisition, subsequent frames will sample different voltages, as well, even when considering the same pixel. The voltage spectral density associated with R_{on} is

$$S_{reset,v} = 4kTR_{on}.$$

Since the noise equivalent bandwidth of the $R_{on}C_{int}$ network is $1/(4R_{on}C_{int})$, we can calculate the voltage rms reset noise:

$$\sigma_{reset,v} = \sqrt{4kTR_{on} \frac{1}{4R_{on}C_{int}}} = \sqrt{\frac{kT}{C_{int}}}.$$

In terms of charge, since $Q_{ph} = C_{int}V$, we have

$$\sigma_{reset,Q} = \sqrt{\sigma_{reset,v}^2 C_{int}^2} = \sqrt{kTC_{int}}.$$

A third noise contribution is due to **quantization noise**. The signal is amplified by the source follower and then transferred to the output; then, an ADC converts it into the digital domain, introducing quantization noise. This contribution can be expressed in terms of voltage at the input of the ADC. The variance of quantization noise is given by

$$\sigma_{quant,v}^2 = \frac{LSB^2}{12}, \quad \sigma_{quant,v} = \frac{LSB}{\sqrt{12}} = \frac{V_{ref}/(2^{N_{bit}})}{\sqrt{12}},$$

being LSB the value of the least significant bit and N_{bit} the number of bits that determines an overall number of levels equal to $2^{N_{bit}}$. This noise can be computed in terms of charge at the follower input simply dividing by the source follower gain (assumed equal to 1) and multiplying by the capacitance value:

$$\sigma_{quant,Q} = \sqrt{\sigma_{quant,v}^2 C_{diode}^2} = \frac{V_{ref}/(2^{N_{bit}})}{\sqrt{12}} C_{diode}$$

Other temporal noise contributions due to the electronics are usually negligible.

PART 3: SIGNAL-TO-NOISE RATIO

The SNR in terms of number of electrons ratio can be computed as $SNR = N_{ph}/\sigma_{total,N}$, where $\sigma_{total,N}$ is the total standard deviation given by the quadratic sum of all noise contributions, expressed in electrons rms:

$$\sigma_{total,N} = \sqrt{\sigma_{ph,shot,N}^2 + \sigma_{dark,shot,N}^2 + \sigma_{reset,N}^2 + \sigma_{quant,N}^2}.$$

Hence,

$$SNR = 20 \cdot \log_{10} \frac{N_{ph}}{\sqrt{\sigma_{ph,shot,N}^2 + \sigma_{dark,shot,N}^2 + \sigma_{reset,N}^2 + \sigma_{quant,N}^2}}.$$

Table 1 summarizes the different noise contributions expressed in terms of both charge and number of electrons. For the given data, we obtain a signal-to-noise ratio of 12.6, which corresponds to 22 dB. This is a *good* value for an image: remember that the human eye can hardly perceive differences in the signal-to-noise ratio (i.e. in the quality of an image) when its values are larger than 30 dB.

Table 1: Noise contributions for SNR calculation

Signal (photocurrent)	4.2×10^{-17} C	263 electrons
Signal shot noise	2.60×10^{-18} C	16 electrons rms
Dark shot noise	5.65×10^{-19} C	3 electrons rms
kTC (reset) noise	1.31×10^{-18} C	8 electrons rms
Quantization noise	1.56×10^{-18} C	10 electrons rms
Total noise	3.35×10^{-18} C	21 electrons rms

We can point out some dependencies of the SNR, by re-writing the expression as follows:

$$SNR = \frac{J_{ph} A_{pix} t_{int} FF}{\sqrt{q(J_d + J_{ph}) A_{pix} t_{int} FF + kT \frac{\varepsilon_{Si} A_{pix} FF}{x_{dep}} + \frac{LSB^2}{12} \left(\frac{\varepsilon_{Si} A_{pix} FF}{x_{dep}} \right)^2}}.$$

Some comments are here reported.

- The SNR increases with the integration time (linearly or with the square root, depending on the dominant noise contribution, see Fig. 6). Apparently, it would be thus preferable to have the longest possible integration time. Pixel saturation, motion blur and DR constraints set a limit on the maximum integration time.
- For large values of signal current i_{ph} , the signal-to-noise ratio goes with the square root of the signal itself, while for small values of the signal the dependence is linear

(see Fig. 7). Note, however, that the shown curve cannot grow indefinitely: the pixel has a limited charge capacity (which limits the maximum photocurrent).

- The signal-to-noise ratio improves with a larger area and with a higher fill factor (unless the rare case when the dominant noise source is quantization noise).

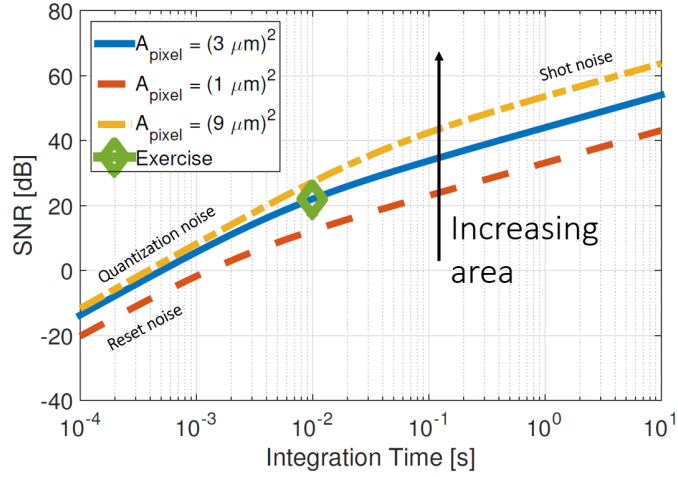

Figure 6: SNR of an APS pixel as a function of the integration time (blue solid curve). The diamond corresponds to the exercise solution.

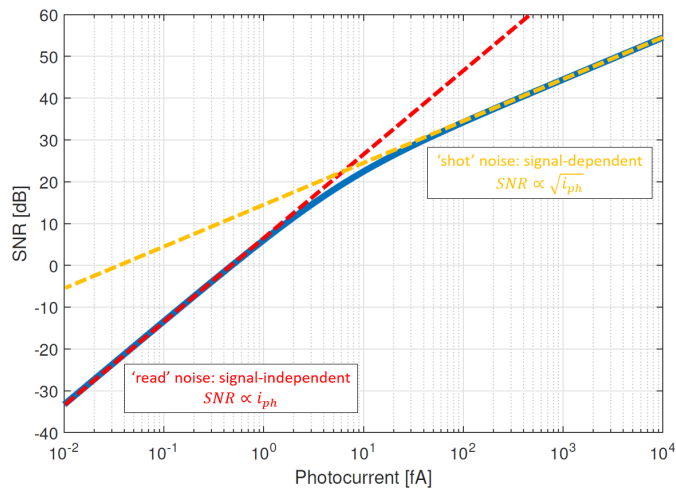

Figure 7: Signal-to-noise ratio of an APS pixel as a function of the photocurrent. As expected, the higher the photocurrent, the higher the SNR.